

# MEDICAL

## CART COMPANY



The **Medical Cart Company Kft** was born in the year 2016 and being a proud Hungarian company, designed in house and all part manufactured locally where possible.

We use materials which are 100% recyclable and ensure that all products have the ability to be refurbished after many years of use and adapted to the changing needs of users with minimal effort.

Our designs are affordable, simple, timeless and functional and we follow the basic rules :



### **Ergonomic**

Simple lightweight design for easy sit to stand adjustment



### **Smooth and easy to clean surfaces**

To aid quicker and easier cleaning



### **Multi purpose**

Easy integration in a variety of applications  
(choice of laptop or VESA mount)



### **Durable**

Lifetime Warranty



### **Quick setup**

Supplied fully assembled with minimal packaging



We understand, that a standard mounting solution may may fit your need, so we offer fast and affordable customization and products exclusively designed for your companies needs.

We are here to be part of your team, not just just your supplier !



## How to choose your cart ?

We have designed a range of bases to suit the requirements of your equipment and the accessories required to support good use and function. All products are available with and without height adjustment .

So how to choose

- Weight of the equipment to accessories to be supported
- Working height required
- Size of work surface
- Location of accessories

We have a standard range of carts which will most needs or alternatively we can design the cart to your needs.

### Step 1 - choose your Base

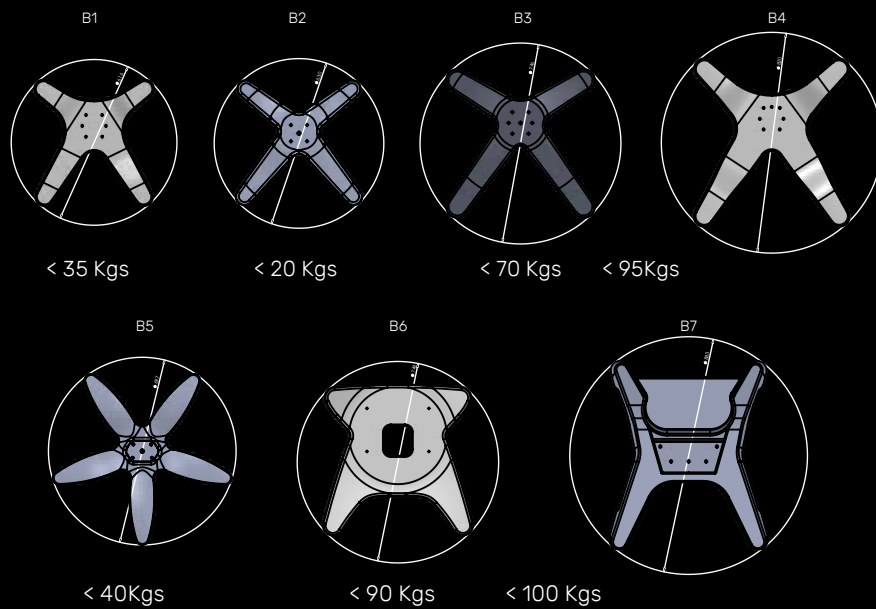

Weights relate to a working height of 1100mm from the floor to keep within the safe practice of EN60601

### Step 2 - choose your Worksurface

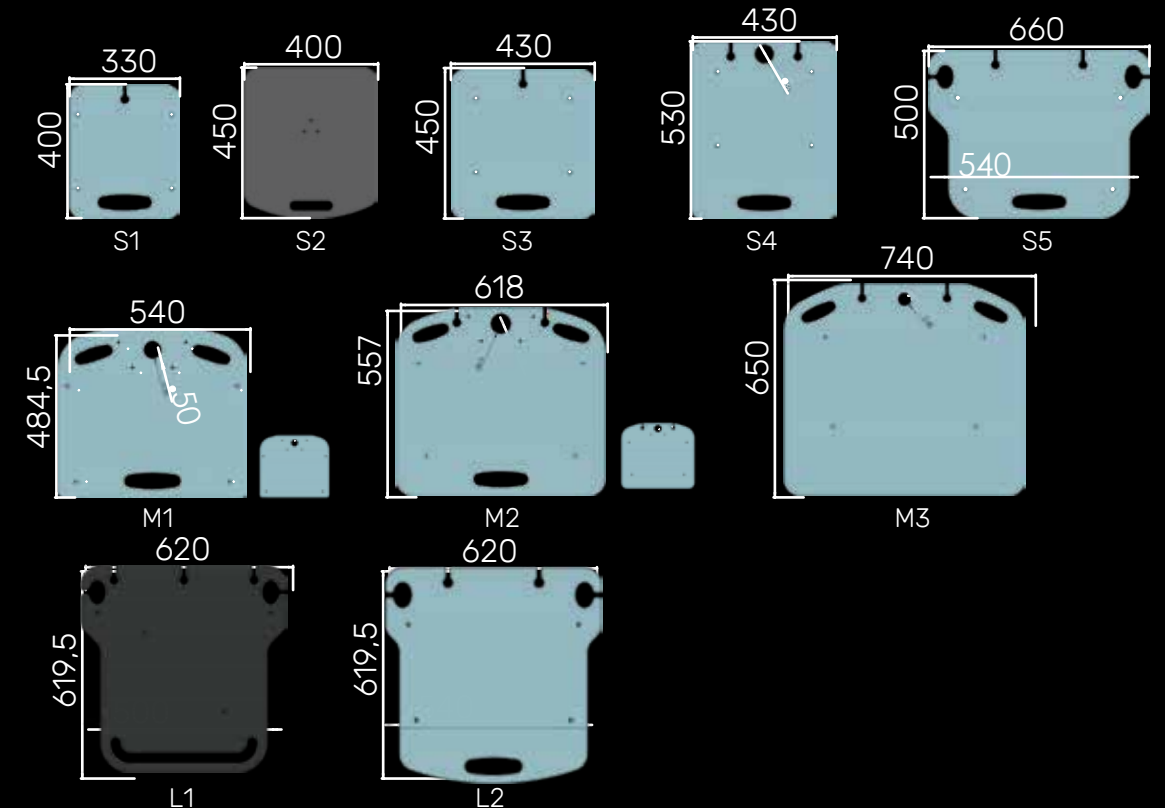

### Step 3 - Adjustable height or fixed height

### Step 4 - Choose your mount and security

### Step 5 - Choose your accessory

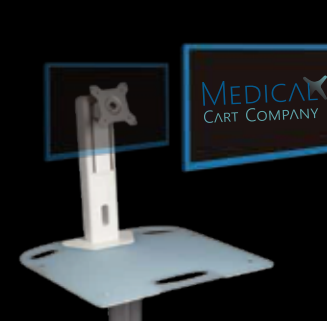

Display mount



Laptop mount



Tablet mount



Standard cart - Available for fast delivery



Budgie range – budget model , light weight, simple.



Giraffe – Configurable Roll stands



Chameleon Range – Configurable work stations with a choice of colours and graphics



Rhino the heavy duty equipment cart with option to add built in Power pack





# Budgie



Limited Budget, Unlimited Solutions

## Accessories

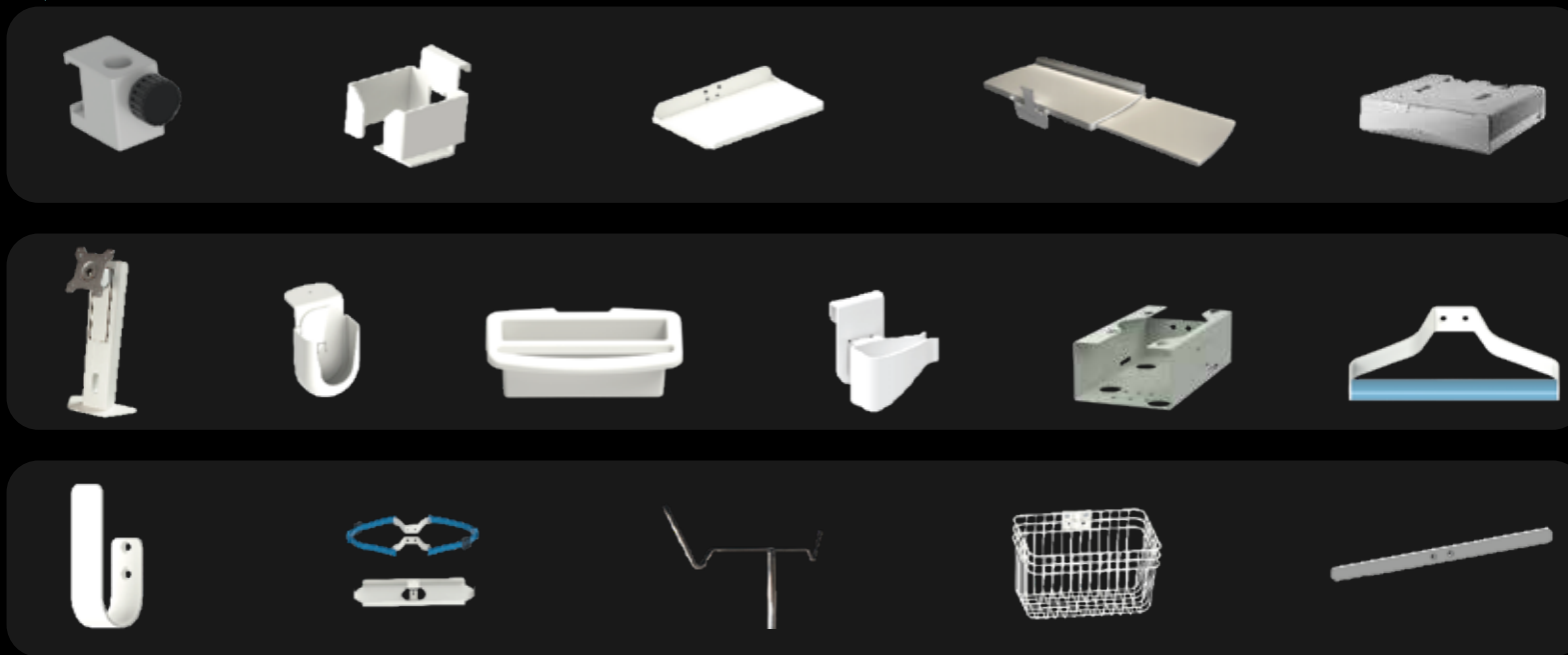

MEDICAL  
CART COMPANY



# Giraffe

Configurable Rollstand solutions for:

- All in one Computers
- Tablets
- Patient monitors
- AV Solutions

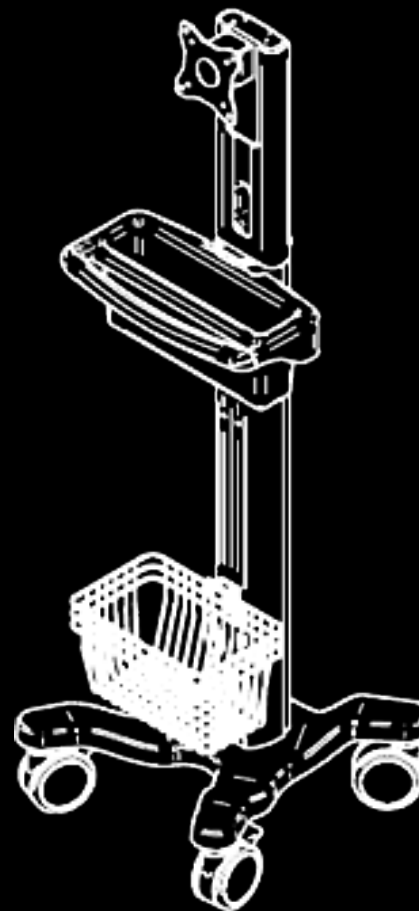



# Chameleons



Custom designe



Custom colour

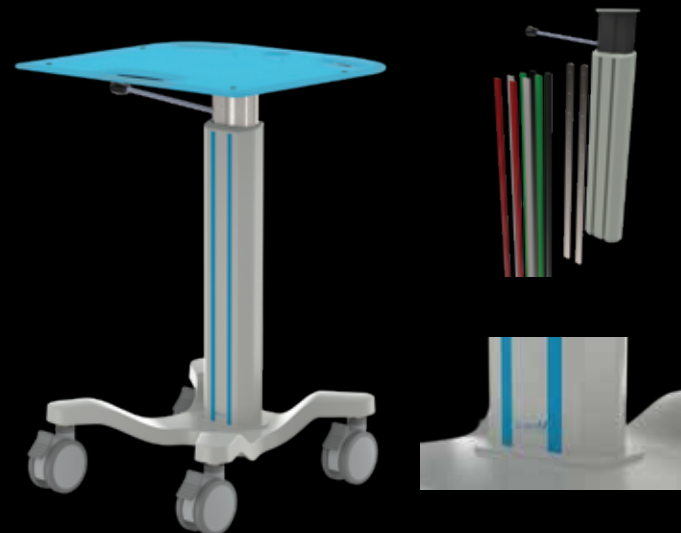



# Rhino

Heavy Duty – configurable cart with optional built in Power Pack





# Drawers

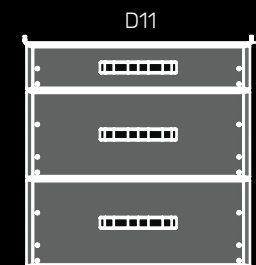
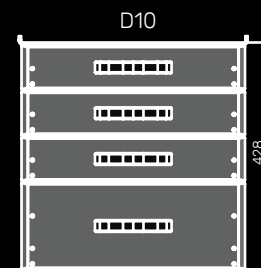
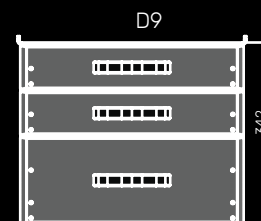
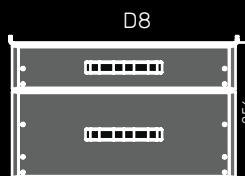
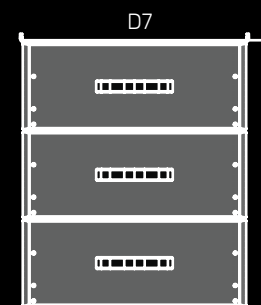
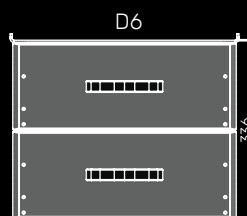
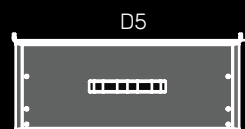
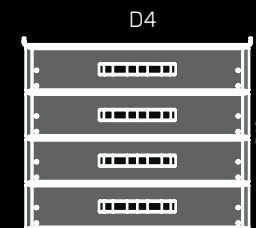
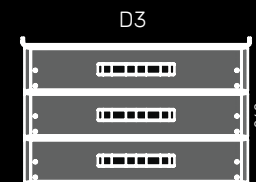
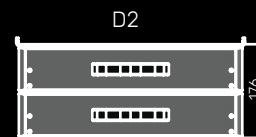
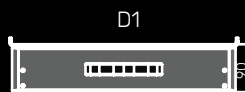

# Power solutions

Medical Isolation Transformers **for added safety** when using medical technology

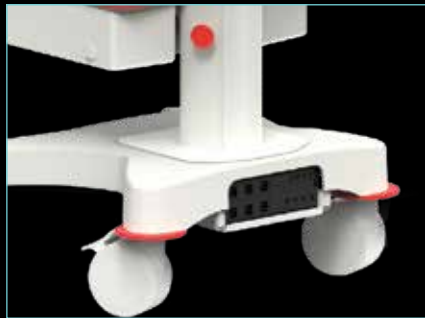

Isolation transformer mounted with hidden cabling

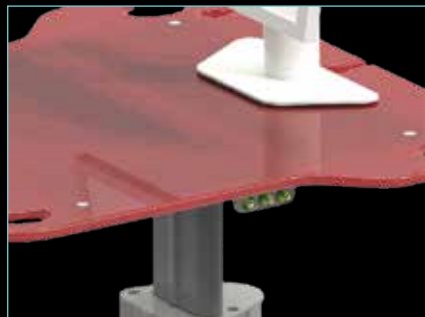

Optional POAG studs



REMOED 300VA A-50W Series Isolation Transformer



REMOED 600VA A-50W Series Isolation Transformer



REMOED 1000VA A-50W Series Isolation Transformer



Medical Power Strip  
5 m



Potential Equalization Cable  
3 m / 5 m



Potential Equalization Socket



Potential Equalization Pin  
15 mm



Potential Equalization Pin  
25 mm



# Circuit and Sensor Arms



# OEM, OODM Design

